



KTC Standard One Cut Risers®

Kinto Canada Ltd has accomplished a standardization of clamp risers. The innovation, called **One Cut Risers®**, provides fixture shops with the real solution of timing and cost saving. These standard risers include 3 options: **One Piece Casting Aluminum Risers**, **Two Piece Extruded Risers** and **Three Piece Universal Risers**. Their major common characters are as below:

- Supplied height from 2.5" up to 12" with an increment of up to 2";
- All attachment holes to clamps and fixture bases are pre-tapped or drilled;
- Ease of installation.

By selecting an appropriate type and size, the risers can be used instantly without any extra machining work. Only under rare circumstances, a simple cut may be required. By default, the thread hole patterns are built to fit De-Sta-Co clamps. Customized patterns are also acceptable.

One Piece Casting Aluminum Risers

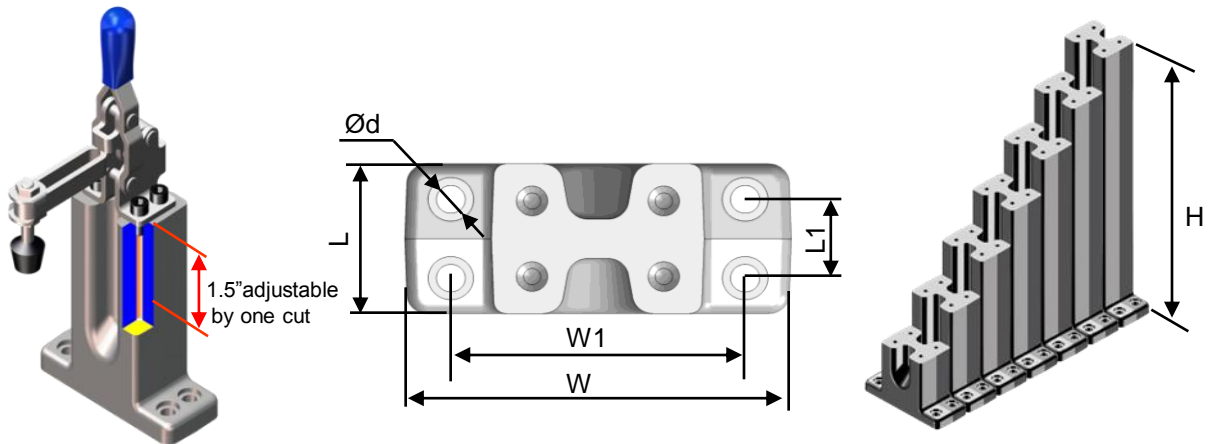

Item Number	Part Number	H (in)	W (in)	W1 (in)	L (in)	L1 (in)	$\varnothing d$ (in)
1	KTC-RSA-2025	2.5	3.386	2.559	1.378	0.610	0.276
2	KTC-RSA-2040	4.0	3.386	2.559	1.378	0.610	0.276
3	KTC-RSA-2055	5.5	3.386	2.559	1.378	0.610	0.276
4	KTC-RSA-2070	7.0	3.386	2.559	1.378	0.610	0.276
5	KTC-RSA-2085	8.5	3.386	2.559	1.378	0.610	0.276
6	KTC-RSA-2100	10.0	3.386	2.559	1.378	0.610	0.276
7	KTC-RSA-2115	11.5	3.386	2.559	1.378	0.610	0.276

Note: 1) The thread hole pattern fits 202 clamps of DE-STA-CO and Screw size to be 10-32 or M5 ;

2) Material and Heat treatment: ZL114(A13570)/T5;

3D models are available at www.kintocanada.com



Item Number	Part Number	H (in)	W (in)	W1 (in)	L (in)	L1 (in)	Ød (in)
1	KTC-RSA-4025	2.5	3.622	2.795	1.496	0.787	0.276
2	KTC-RSA-4040	4.0	3.622	2.795	1.496	0.787	0.276
3	KTC-RSA-4055	5.5	3.622	2.795	1.496	0.787	0.276
4	KTC-RSA-4070	7.0	3.622	2.795	1.496	0.787	0.276
5	KTC-RSA-4085	8.5	3.622	2.795	1.496	0.787	0.276
6	KTC-RSA-4100	10.0	3.622	2.795	1.496	0.787	0.276
7	KTC-RSA-4115	11.5	3.622	2.795	1.496	0.787	0.276

Note: 1) The thread hole pattern fits 207 clamps of DE-STA-CO and Screw size to be ¼-20 or M6;
2) Material and Heat treatment: ZL114(A13570)/T5;
3D models are available at www.kintocanada.com

Two Piece Extruded Risers

In addition to the features of *One Piece Casting Aluminum Risers*, the *Two Piece Extruded Risers* provide more flexibilities:

- The adjustable thread depth increased to 2";
- The angular adjustability of +- 5° around its dowel pin.

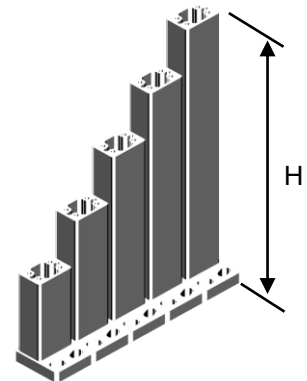
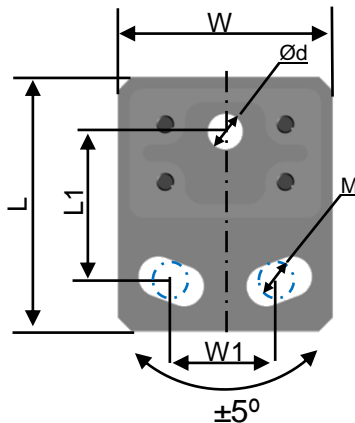
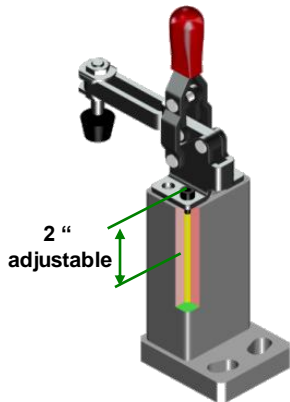

Item #	Part Number	H (in)	W (in)	W1 (in)	L(in)	L1(in)	Ød (in)	M
1	KTC-RSB-2040	4.0	1.69	0.949	1.87	0.973	10	¼-20
2	KTC-RSB-2060	6.0	1.69	0.949	1.87	0.973	10	¼-20
3	KTC-RSB-2080	8.0	1.69	0.949	1.87	0.973	10	¼-20
4	KTC-RSB-2100	10.0	1.69	0.949	1.87	0.973	10	¼-20
5	KTC-RSB-2120	12.0	1.69	0.949	1.87	0.973	10	¼-20

Note: 1) The thread hole pattern fits 202 clamps of DE-STA-CO and Screw size to be 10-32 or M5
2) Material and Heat treatment: 6063/T6

3D models are available at www.kintocanada.com



Item #	Part Number	H (in)	W (in)	W1 (in)	L(in)	L1(in)	Ød (in)	M
1	KTC-RSB-4040	4.0	1.98	1.122	2.28	1.150	10	5/16-24
2	KTC-RSB-4060	6.0	1.98	1.122	2.28	1.150	10	5/16-24
3	KTC-RSB-4080	8.0	1.98	1.122	2.28	1.150	10	5/16-24
4	KTC-RSB-4100	10.0	1.98	1.122	2.28	1.150	10	5/16-24
5	KTC-RSB-4120	12.0	1.98	1.122	2.28	1.150	10	5/16-24

Note: 1) The thread hole pattern fits 207 clamps of DE-STA-CO and Screw size to be ¼-20 or M6

2) Material and Heat treatment: 6063/T6

3D models are available at www.kintocanada.com



Three Piece Universal Risers.

In addition to the features of **Two Piece Extruded Risers**, The **Three Piece Universal Risers** give you the ability to adjust the clamps to any 3D orientations:

- +90° adjustable around their horizontal axis.
- 4 optional positions around their vertical axis.

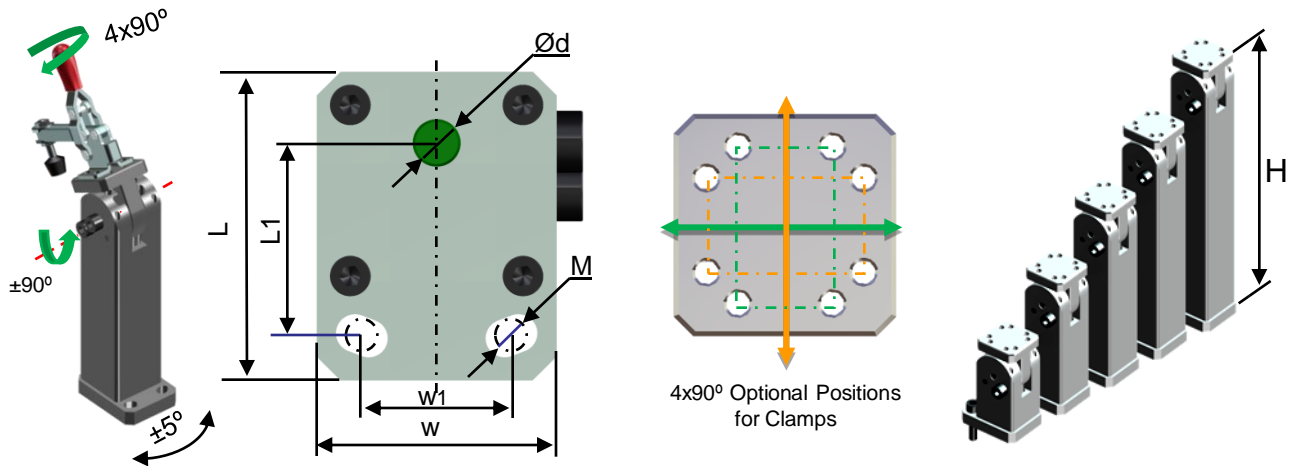

Item#	Part Number	H (in)	W (in)	W1 (in)	L(in)	L1(in)	Ød(in)	M(in)
1	KTC-RSC-2*(4*)040	4.0	1.97	1.19	2.56	1.61	0.394	5/16-20
2	KTC-RSC-2*(4*)060	6.0	1.97	1.19	2.56	1.61	0.393	5/16-20
3	KTC-RSC-2*(4*)080	8.0	1.97	1.19	2.56	1.61	0.393	5/16-20
4	KTC-RSC-2*(4*)100	10	1.97	1.19	2.56	1.61	0.393	5/16-20
5	KTC-RSC-2*(4*)120	12	1.97	1.19	2.56	1.61	0.393	5/16-20

Note: A) 2*:The thread hole pattern fits 202 clamps of DE-STA-CO and screw size to be 10-32 or M5;

4*:The thread hole pattern fits 207 clamps of DE-STA-CO and screw size to be ¼-20 or M6;

B) Material and Heat treatment: 6063/T6

3D models are available at www.kintocanada.com



KTC One for Two Risers

KTC One for Two aluminum casting risers are designed to provide our customers with another option, when the clamps must be installed at an angle relative to their horizontal position.

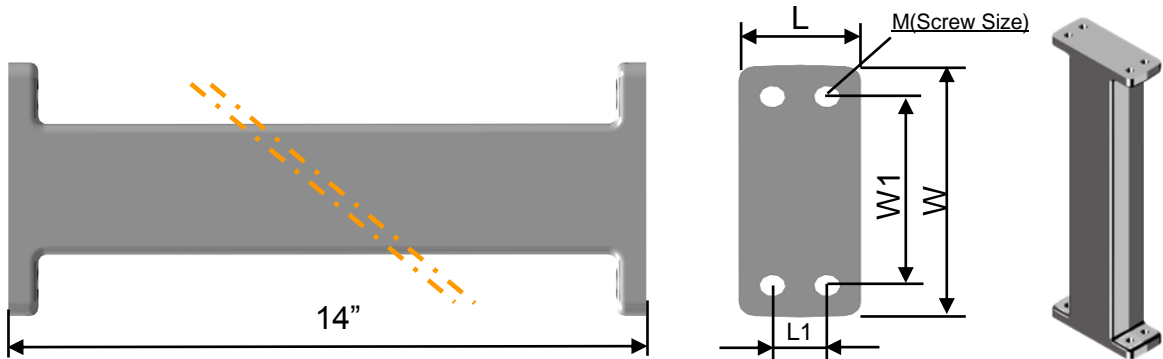

Item #	Part Number	W(in)	W1 (in)	L(in)	L1(in)	M	APPLICATIONS
1	KTC-RS-200	3.386	2.559	1.378	0.610	M6 or 1/4-20	KTC VC-200 series clamps DE-STA-CO 202 clamps CL-253VTC
2	KTC-RS-400	3.622	3.795	1.496	0.787	M6 or 1/4-20	KTC VC-400 series clamps DE-STA-CO 207 clamps CL-453VTC

Material and Heat treatment: ZL114(A13570)/T5
3D models are available at www.kintocanada.com



KTC DIY Extruded Tubes for Risers

KTC DIY tubes are built to provide our customers with the cost saving while building the risers to their own design. The tubes are extruded 6063 aluminum and treated to T5 and then anodized to silver color. The extruded hole patterns cooperate with DE-STA-CO's clamps.

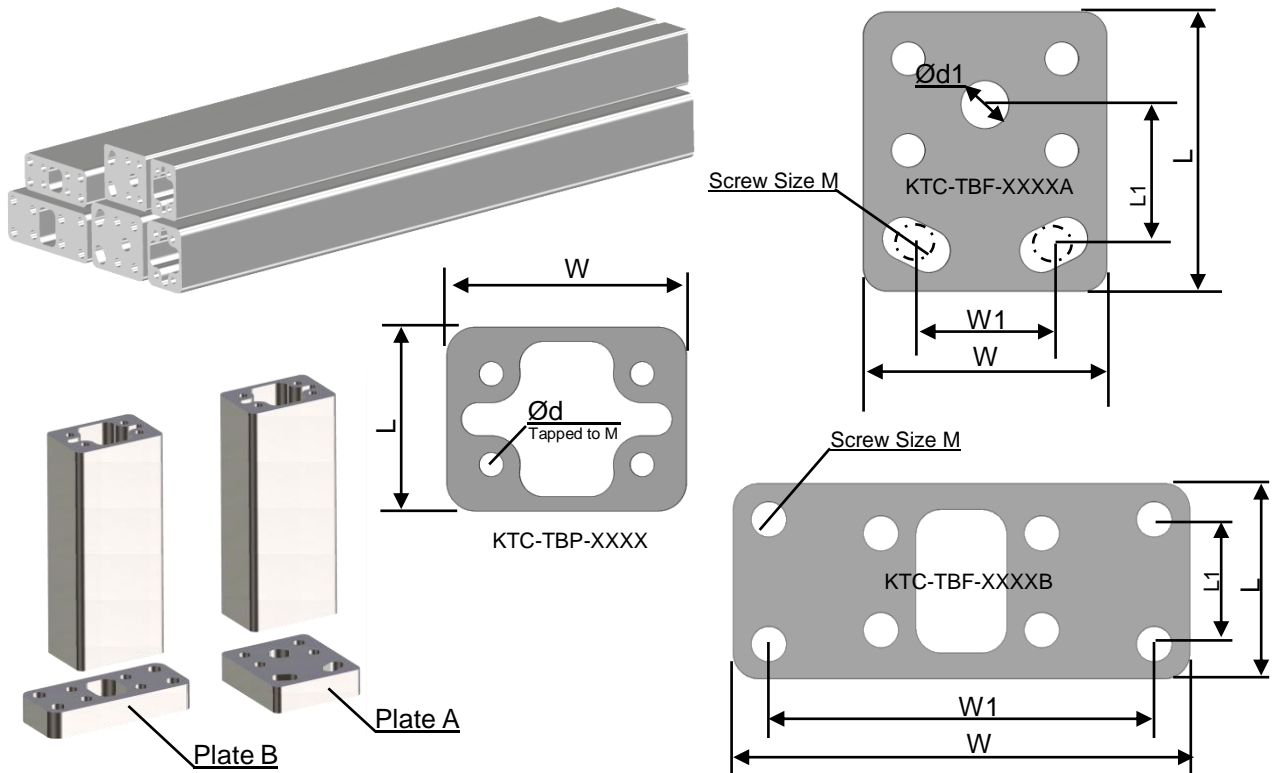

Unit: mm

Item #	Part Number	W	L	W1	L1	d	d1	M	Application	Weight/ft
1	KTC-TBP-2200	42.9	28.5			3.8		M5	202 clamps /DE-STA-CO	1.25 lbs
2	KTC-TBP-2400	50.3 5	38.55			4.9		M6	207 clamps /DE-STA-CO	1.8 lbs
3	KTC-TBF-2200A	42.9	47.5	24.1	24.7		8	M6	To be Plate A for KTC-TBP-2200	3.15lbs
4	KTC-TBF-2200B	78	28.5	61	15.5			M6	To be Plate B for KTC-TBP-2200	2.70lbs
5	KTC-TBF-2400A	50.3 5	58	28.5	29.2		10	M8	To be Plate A for KTC-TBP-2400	4.40lbs
6	KTC-TBF-2400B	90	38.6	76	24.6			M8	To be Plate B for KTC-TBP-2400	4.80lbs

3D models are available at www.kintocanada.com